

## Product Overview

The Io Moon LED Light Module is just one of the new Moon Series of LED Light Modules now available from LuxDrive. The Io Moon combines the Jupiter® Series High-Power LED from Nichia® with a proprietary thermal-management technique, Therma-pore™. Using an ultra-thin PC Board and Therma-Pore™ heat-transfer technology, the thermal resistance between the LED junction and the heat sink has been minimized, allowing for high luminous intensity in a package that is low-profile and is extremely versatile. Electrical isolation allows the Io Moon to be mounted directly to the heat-sink surface. The Io Moon is available in cool and warm white, and with primary optics producing 35° and 70° beam widths.

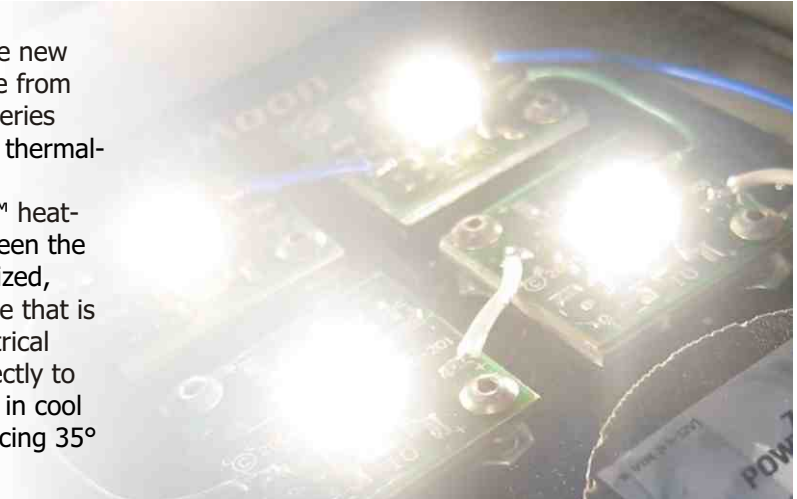

(4) 04020 Io Moon LED Modules powered by LuxDrive's 2008 PowerPuck @ 9.6V. (PowerPuck Model 02008-700)

## Specifications

### Electrical Specifications

Forward Current ( $I_F$ )	500 mA
Pulse Forward Current** ( $I_{FP}$ )	1000 mA
Allowable Reverse Current ( $I_R$ )	85 mA
Power Dissipation ( $P_D$ )	2.1 W
Operating Temperature ( $T_{OPR}$ )	-30 to +85°C
Storage temperature.	-40 to +100°C
Recommended Operating Current ( $I_{OUT}$ )	350 mA

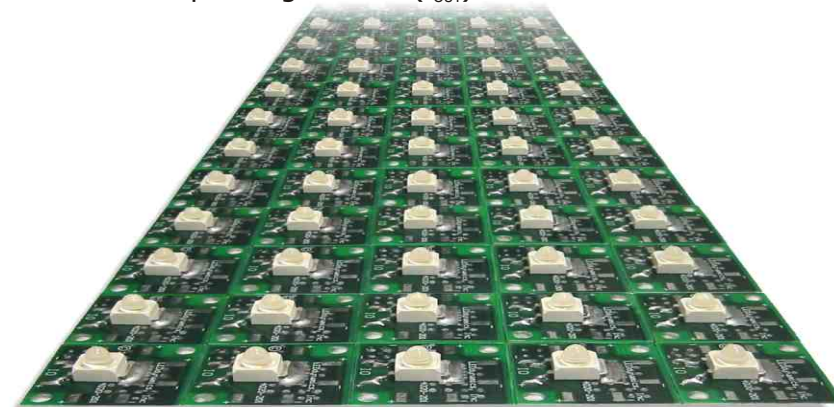

**Custom arrays, PCBs (metal-core, FR4), drivers and control systems are available. Contact LuxDrive for more information.**

### Features

- High luminous intensity
- Thin package
- Simple connection
- Superior life span and reliability
- Energy efficient

### Typical Applications

- Solar & Landscape Lighting
- Architectural Lighting
- Track Lighting
- Automotive & Marine Lighting
- Portable Lighting & Flashlights
- Point of Purchase Lighting
- Desk & Reading Lamps
- Signal & marker Lighting
- Flashing & Strobe Lighting
- Cabinet & Display Case Lighting
- Sign & Channel Letters
- Much More...

\* - Jupiter is a registered trademark of Nichia Chemical Corporation  
\*\* -  $I_{FP}$  Conditions: Pulse width <10ms, duty cycle <10%

## Part Number Identification Table

Part Number	I <sub>F</sub>	View Angle	Color	Nichia Part Number	V <sub>F</sub>		Light output
					typ	max	
04020-CW-35	350mA	35°	Cool White	NCCW023	3.8V	4.3V	42(lm)
04020-CW-70	350mA	70°	Cool White	NCCW022	3.8V	4.3V	42 (lm)
04020-WW-35	350mA	35°	Warm White	NCCL023	3.8V	4.3V	32 (lm)
04020-WW-70	350mA	70°	Warm White	NCCL022	3.8V	4.3V	32(lm)

### Heat Sinking

The Io will operate safely in free air (all surfaces exposed to air) at the recommended operating current. For operation at higher currents, the module should be attached to additional heat sinking. If the module is attached to a thermal insulator (wood or plastic), an additional metal plate with increased area exposed to free air needs to be provided.

### Optical Properties

Available in 35 and 70 degree beam widths.

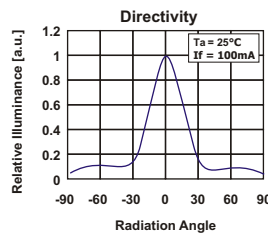

04020-XX-35

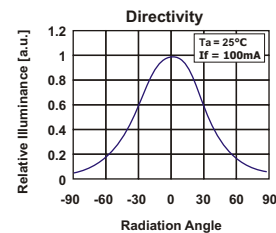

04020-XX-70

### Physical Specifications

**Material:** The Io Moon LED Light Module consists of a printed circuit board, containing the Nichia Jupiter LED, using the Therma-pore™ thermal management technique.

**Mounting:** The Io Moon LED Light Module is 1.00" square and has two mounting holes for standard #4 screws. The mounting centers are shown in Figure 1.

**Center of Emissivity:** Figure 2 shows the center of emissivity for the LED.

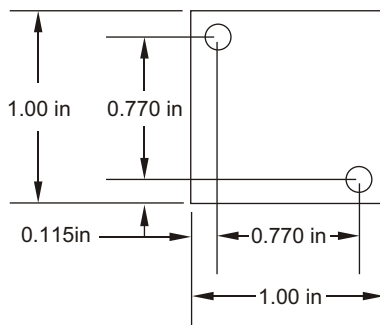

**Figure 1.**  
Mounting centers

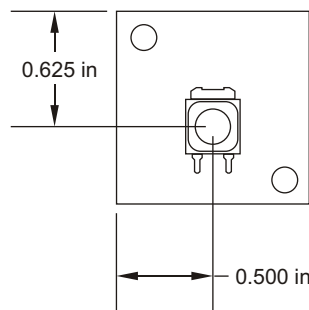

**Figure 2.**  
Center of emissivity

### Recommended Drivers

LuxDrive offers a line of drivers designed for use with High-Power LEDs. Several of these will provide the correct operating power for one or more Io modules. The choice of driver will depend upon number of Io modules to be driven and the input voltage source. See the full line of LuxDrive products on our web site at [www.LuxDrive.com](http://www.LuxDrive.com)